

# Development and Performance Evaluation of an Oil Palm Fruit Digester

Adepoju Bola Fashina, Oludare Sunday Durodola\*, Ibrahim Adebayo Hammed

Department of Agricultural Engineering, Ladoke Akintola University of Technology, Ogbomosho, Nigeria

## Email address:

durodolaoludare@gmail.com (O. S. Durodola), hammedibrahim116@gmail.com (I. A. Hammed)

\*Corresponding author

## To cite this article:

Adepoju Bola Fashina, Oludare Sunday Durodola, Ibrahim Adebayo Hammed. Development and Performance Evaluation of an Oil Palm Fruit Digester. *Bioprocess Engineering*. Vol. 1, No. 2, 2017, pp. 49-53. doi: 10.11648/j.be.20170102.13

**Received:** May 8, 2017; **Accepted:** May 17, 2017; **Published:** June 28, 2017

---

**Abstract:** An oil palm fruit digester was designed, fabricated and tested. The materials for fabrication were sourced locally. The machine was tested for throughput capacity (Dc) and efficiency ( $\eta$ ). Average throughput capacity of 330.91 kg/h and efficiency of 62.35% were obtained. Rate of digestion increased with the increase in mass of the digesting palm fruits while the efficiency of the oil palm fruit digester decreased with increase in mass of the digesting palm fruit in some cases. The machine is simple to operate and maintain.

**Keywords:** Digester, Oil Palm Fruit, *Dura*, *Tenera*, *Pisifera*

---

## 1. Introduction

The Oil Palm (*Elaeis guineensis*) originated from the tropical rain forest region of West Africa; the main belt runs through the southern latitudes of Cameroon, Côte d'Ivoire, Ghana, Liberia, Nigeria, Sierra Leone, and Togo and into the equatorial region of Angola and the Congo [1]. The fruit is made up of an outer skin (exocarp), a pulpy skin (mesocarp) containing the palm oil in fibrous matrix, central nut consisting of shell carp) and the kernel which itself contains palm kernel oil [1].

Three varieties of oil palm fruit exist: the *dura*, *pisifera* and *tenera*. The *dura* consists of a thick pericarp or exocarp, 2–8 mm thick, a thin mesocarp (which is responsible for the low palm oil content of this variety), thick endocarp (shell) and generally large kernels (which make it suitable for kernel oil production). Its mesocarp content is 35–55%. The *pisifera* has fruits which possess thick mesocarp (with very little oil content), no endocarp (shellless) and with small kernel. The *tenera* type possesses thick mesocarp (much pulp), thin endocarp and a reasonably sized kernel. It is the product of the cross of *pisifera* and *dura*. It is useful in the production of mesocarp oil but less kernel oil when compared with the *dura* variety [2]. Also, [3] reported that the ratio of polyunsaturated fatty acids was higher in *pisifera* than *dura* and *tenera*.

Processing of oil palm fruit yields mainly palm oil and palm kernel oil and palm and fibre as by-products. The palm

nut when further processed yields shell, kernel oil and palm kernel cake, which have numerous domestic and industrial applications [4]. The key process in the oil palm production process is fruit digestion. Digestion as the process by which boiled or sterilized fruits are macerated for easy separation of oil from the fibre [5]. This involves crushing and detachment of the heat-weakened mesocarp from fruit nuts. Digestion and oil extraction are the most tedious and essential operations in traditional palm fruit processing, therefore, early efforts concentrated on these tasks [6].

According to [7], a digester consists of a shaft to which stirring arms are attached and these stir and rub the fruits so loosening the pulp from the nuts and at the same time breaking open the oil cells of the pulp. Digester comes in two categories and these are vertical and horizontal digesters [8]. In a vertical digester, digestion of fruit mesocarp is done by a vertical shaft fitted with beater arms at specified orientation and spacing on the shaft; while in horizontal digester, digestion is done by the beater arms which also transport macerated fruits from the digester inlet to the outlet [9].

However, farmers and oil palm processors carry out the process of oil palm fruit digestion by manual means. Local digestion of palm fruit is usually performed by the use of mortar and pestle or by barefoot mostly by women. These primitive methods of digestions are usually accompanied by slow and very low digestion and production rates, unhygienic, time-consuming, drudgery and the fact that a lot

of human energy is usually expended during digestion. In the findings of [10], factors like transport costs, high cost of plantation rentals, and poor extraction processes were most critical to inhabiting profitable palm oil processing.

The manual digestion process of the oil palm fruit is not efficient and involves drudgery. Thus, one of the constraints in the mechanization of small-scale palm oil mills is the unavailability of an efficient, small scale palm fruit digester of which this research work chose to address. The research covered the fabrication, testing and evaluation of an oil palm fruit digester. The *pisfera* specie was used. After consideration of existing designs, bevel gear was incorporated into the design. The bevel gear is to change the axis of rotational motion and reduce the speed of rotation. The research work was carried out in Agricultural Engineering Department, Ladoke Akintola University of Technology, Ogbomoso, Oyo State, Nigeria.

## 2. Design Analyses and Calculation

The major designs were on the belt length, power requirement, torque developed, design of drive mechanism and speed of stirrer.

### 2.1. Belt Design

The length of the belt was determined using the Kurmi and Gupta [11] formula below:

$$L = \frac{\pi}{2}(D_1 + D_2) + 2x + \frac{(D_1 - D_2)^2}{4x} \quad (1)$$

Where L is total length of the belt,  $D_1$  is the diameter of the driving pulley,  $D_2$  is the diameter of the driven pulley, and X is distance between the centres of the two pulleys. The belt length is 1165.52 mm.

### 2.2. Speed of the Stirrer

Using the theory that the product of the diameter and speed of one pulley is equal to that of the other; [9]: the hammer speed was calculated by using equation:

$$D_1 N_1 = D_2 N_2 \quad (2)$$

Where  $N_2$  is the speed of the bevel gear (rpm),  $D_1$  is the diameter of the pulley on the petrol engine,  $D_2$  is the diameter of pulley attached to the bevel gear,  $N_1$  is the speed of the petrol engine (rpm). Therefore, the speed of the bevel gear is 1584 rpm

### 2.3. The Speed Reduction from the Gear to the Stirrer

$$N_1 T_1 = N_2 T_2 \quad (3)$$

Where  $N_2$  is the speed of the driven gear (rpm),  $N_1$  is the speed of the driver gear (rpm),  $T_1$  is the number of teeth of the driver gear,  $T_2$  is the number of teeth of the driven gear. Therefore, the speed of the driven gear is 414.86 rpm.

Since the stirrer is attached to the driven gear, the speed of the driven gear was equal to the speed of the stirrer.

### 2.4. Centrifugal Force Developed in the System

Centrifugal force ( $F_c$ ) developed in the barrel was deduced as given by [12]:

$$F_c = M\omega^2 r_1 \quad (4)$$

Where M is the inertia mass of the hammer before attaching to the shaft (kg),  $\omega$  is the angular velocity of the stirrer shaft (rad/sec) and  $r_1$  is the radius of the pulley on the gear (m)

$$\text{But, } \omega = \frac{2\pi N_2}{60} \quad (5)$$

Therefore, equations (4) and (5) become

$$F_c = M \left[ \frac{2\pi N_2}{60} \right]^2 r_1 \quad (6)$$

Centrifugal force developed in the stirrer as obtained from [6] was 63.2 N.

### 2.5. Torque Developed

The torque in the design is considered here so that the idea of the capacity or power of the petrol engine to be used can be determined. Using the expression by Kurmi and Gupta [11] that torque (T) is equal to the product of force and radius, the value of the torque developed on the stirrer shaft was calculated using:

$$T = F_c r_2 \quad (7)$$

Where  $F_c$  is the centrifugal force developed in the barrel and  $r_2$  is the radius of stirrer shaft. Therefore the torque developed in the system would be 1.58 Nm.

### 2.6. Power Requirement and Tension in the Belt

The power requirement of the digester was determined with the expression by Kurmi and Gupta [11] which states that power is the product of torque (T) and angular velocity ( $\omega$ ) as:

$$P = T\omega \quad (8)$$

But;

$$\omega = \frac{2\pi N_2}{60} \quad (9)$$

Therefore, equations (7) and (8) become:

$$P = \frac{2\pi N_2 T}{60} \quad (10)$$

Where P is the Power (Watt), N is the speed of shaft (rpm), T is the torque required to turn the shaft (Nm). Therefore 5.5 hp petrol engine was selected to give the required torque in the system.

### 2.7. Tension in the V-belt

The tension in the v-belt was deduced by applying Kurmi and Gupta [11] formula:

$$\frac{T_1}{T_2} = e^{\theta\mu} \quad (11)$$

Where  $T_1$  is the tension on the tight side of the belt,  $T_2$  is the tension on the slack side of the belt,  $\mu$  is the coefficient of friction and  $\theta$  is the angle of wrap in radians. But for v-belts,

$$\frac{T_1}{T_2} = 3 \quad (12)$$

Where the factor 3 is a constant for v-belts

$$\text{Therefore, } T_1 = 3T_2 \quad (13)$$

$$\text{Since } T_1 = F_c \quad (14)$$

$$\text{Therefore, } T_2 = \frac{F_c}{3} \quad (15)$$

$$T_2 = 21.1 \text{ N}$$

Effective tension on the belt then became 21.1N.

### 3. Materials and Methods

#### 3.1. Description of the Oil Palm Fruit Digester

The oil palm fruit digester consists of the following components; frame, hammers, stirrer shaft, hopper/digesting chamber, discharge chute, fibre and nut outlet, gear support frame, bevel gear, vee belt and pulley and petrol engine (Figures 1, 2, 3 and Table 1).

- i. Frame: The frame usually provides rigid and skeletal support for the entire system. Apart from the four-corner support of main frame work, it consisted of two compartments, which were the support for the digesting chamber and another support for the petrol engine. The frame is made of 50.8 mm × 50.8 mm angle iron bar. It has a length of 445 mm, width 364 mm and height of 360 mm. The welding provided very

rigid joints. The gear support frame provided support for the bevel gear. It is of 50.8 mm × 50.8 mm angle iron bar with length of 423 mm, width of 227 mm and height of 40 mm. The frame was attached to the digesting chamber by means of bolts and nuts.

- ii. Hammers: The hammers were four in number. They were made of mild steel of 16 mm diameter and length of 170 mm. Each of the hammers was welded on the stirrer shaft at a vertical distance of 100 mm.
- iii. Stirrer shaft: The stirrer shaft was a steel central shaft providing the size reduction effect on the oil palm fruits and was attached to the bevel gear drive. The diameter was 25 mm.
- iv. Hopper/Digesting chamber: The hopper was an opening on the digesting chamber. This unit housed the stirrer shaft and hammers during operation. It was a cylindrical drum placed vertically with a top opening. The bottom part was closed with a cylindrical flange having a central opening of 42 mm that would aid the collection of crude oil after digestion. It was made of 2 mm mild steel sheet with a diameter of 420 mm and a height of 510 mm.

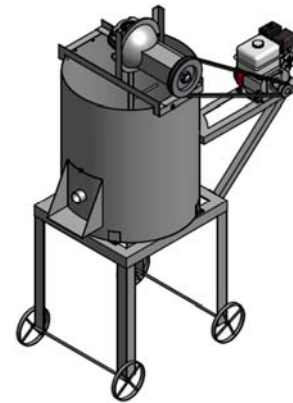

Figure 1. Isometric view of the machine.

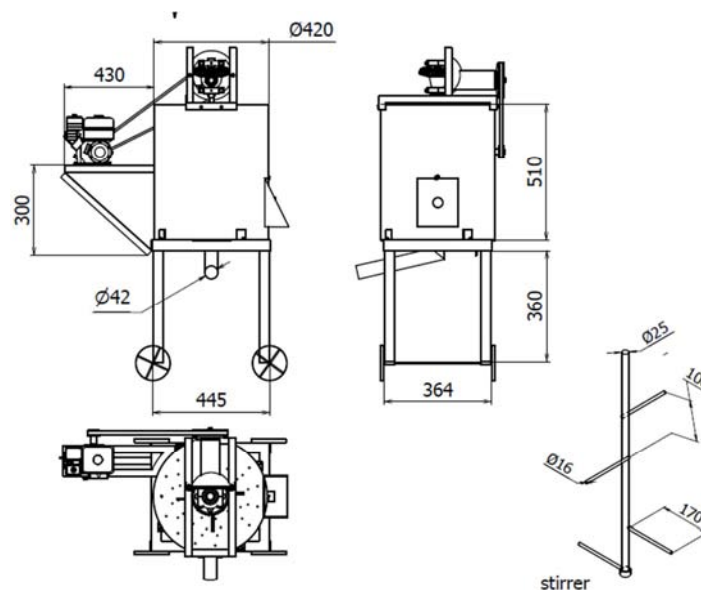

Figure 2. Orthographic view of the machine.

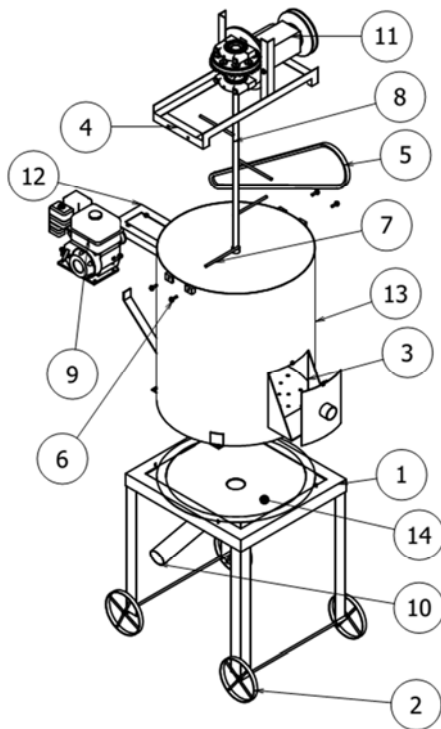

Figure 3. Exploded view of the machine.

Table 1. List of the machine parts.

14	Palm oil collector
13	Hopper/digesting chamber
12	Engine support frame
11	Bevel gear assembly
10	Discharge chute
9	Petrol engine
8	Stirrer
7	Hammer
6	Bolt
5	Vee belt
4	Gear support frame
3	Fibre/nut outlet
2	Roller
1	Frame

List of parts

- v. Discharge chute: This was a continuation of the cylindrical flange at the bottom of the digesting chamber. It directed the flow of the crude palm oil to a receptacle.
- vi. Fibre and nut outlet: The fibre and nut outlet was a square opening on the side of the digesting chamber with the dimension of 150 mm.
- vii. Bevel gear: The bevel gear had a pulley of 125 mm diameter attached to it. The number of teeth of the driver gear was 11 and the number of teeth of the driven gear was 42. It transmitted power to the stirrer shaft at reduced speed and increased torque.
- viii. Vee belt: The vee belt transmitted power and motion from the petrol engine to the bevel gear via the pulley on the petrol engine and the bevel gear.
- ix. Petrol engine: A 4.1 kW petrol engine was used to

power the machine and it was mounted on the frame by means of bolts and nuts.

### 3.2. Methods

#### 3.2.1. Fabrication of the Machine

The developed palm fruit digester was designed, fabricated and assembled at Agricultural Engineering Department Workshop, Ladoke Akintola University of Technology, Ogbomosho, Oyo State. The tools used in the fabrication processes were drilling machine, milling machine, hand grinder and an electrical arc welding machine.

#### 3.2.2. Evaluation of the Machine

The experiments were carried out using the *pisifera* oil palm fruits. In the experiments, the performance of the digester was evaluated by determining the throughput capacity,  $D_c$  (kg/h) and efficiency,  $\eta$  (%) as given by [13].

$$D_c = \frac{W}{T_a} \times 60 \quad (16)$$

Where  $D_c$  is the rate of digestion (kg/h) and  $T_a$  is the average digestion time (minutes).

$$\eta = \frac{W_d}{W} \times 100 \quad (17)$$

Where  $\eta$  is the efficiency (%),  $W_d$  is the weight of the digested fruits collected at the outlet of the digester (kg) and  $W$  is the initial weight of the palm fruit fed into the digester (kg).

Samples of the *pisifera* palm fruit of weight 5, 10, 15 and 20 kg were fed into the digester twice at an operational speed of 414.86 rpm with water of 4, 6, 8 and 10 litres respectively at intervals during the operation. A stop watch was used to record the time taken for digestion for each of the trials.

## 4. Results and Discussion

Data from the experiment in Table 2 showed that increase in mass of the palm fruits increases the digestion time. The digester performance result presented in Table 3 shows that the average throughput capacity,  $D_c$  and efficiency,  $\eta$  are 330.91kg/h and 62.35% respectively. This corresponds to the result of [13] and [14]. Also, it revealed that increase in the mass of the palm fruits increases the throughput,  $D_c$ .

In addition, the efficiency of the palm fruit digester increased with increase in the mass of the palm fruits from 5kg to 10kg while the efficiency decreased with increase from 10kg to 15kg. The efficiency then increased when the masses of the parboiled palm fruits was increased from 15kg to 20kg.

The developed oil palm fruit digester was found to perform well with all the mass of the fresh palm fruits poured into it when tested. The highest digesting efficiency of 64.40% with a throughput of 303.03kg/h was obtained when an initial palm fruit mass of 10kg was digested. The amounts of digested and undigested fruit produced from this were 3.58kg and 6.42kg respectively.

**Table 2.** Determination of weight of digested, undigested fruits and digestion time.

Test	Initial weight of palm fruit, W(kg)	Weight of digested fruit $W_d$ (kg)	Weight of undigested fruit, $W_u$ (kg)	Digestion time $T_a$ (min)
1	5	1.75	3.25	1.76
2	5	1.90	3.10	1.50
3	10	3.70	6.30	1.93
4	10	3.45	6.55	2.02
5	15	5.75	9.25	2.37
6	15	6.10	8.90	2.42
7	20	7.75	12.25	2.63
8	20	7.70	12.30	2.57

**Table 3.** Determination of digesting capacity and efficiency of the developed oil palm fruit digester.

S/N	Initial weight of palm fruit W(kg)	Average weight of digested fruit $W_d$ (kg)	Average weight of undigested fruit $W_u$ (kg)	Average Digestion time	Throughput	Efficiency
				$T_a$ (min)	$D_c$ (kg/h)	$\eta$ (%)
1	5	1.83	3.17	1.63	184.05	63.40
2	10	3.58	6.42	1.98	303.03	64.20
3	15	5.93	9.07	2.40	375.00	60.46
4	20	7.73	12.27	2.60	461.54	61.35

## 5. Conclusion

An oil palm fruit digester was designed, fabricated and performance evaluation test carried out. The result showed that the machine has an average efficiency of 62.35% and throughput capacity of 330.91kg/h. The oil palm fruit digester so far developed is easy to operate and maintain. Testing and performance evaluation of the system showed that the system can be use by farm cooperatives and women in rural communities.

## References

- [1] Food Agriculture Organization, Small-scale palm oil processing, *FAO Agricultural Services Bulletin* 148.2002.
- [2] Opeke, L. K.; *Tropical tree crops*, Chichester, New York, Brisbane, Toronto, Singapore: John Wiley and Sons, 1982.
- [3] Mathieu N., Charles K. T., Frank N. E. G., Jeanne N. Y., Fatty Acids and Tocopherols Contents of Cameroon Oil Palm from Three Varieties of *Elaeis guineensis jack*, *International Journal of Nutrition and Food Sciences*. Vol. 5, No. 1, 2016, Pp. 68-71.
- [4] Owolarafe O. K., Faborode M. O and Ajibola O. O. "Comparative Evaluation of the Digester Screw Press and a Hand Operated Hydraulic Press for Palm Fruit Processing" *Journal of Food Engineering*, Vol. 52, 2002, pp. 249–255.
- [5] Nchanji Y. K., Tataw O, Nkongho R. N. and Levang P.; Artisanal Milling of Palm Oil in Cameroon, *Working Paper* 128, 2013, Bogor, Indonesia: CIFOR.
- [6] Adeniyi O. R., Ogunsola G. O and Oluwusi D., "Methods of Palm Oil Processing in Ogun State" *American International Journal of Contemporary Research*, Vol.4, No.8, 2014, pp. 173-179.
- [7] Nwankwojike B. N, Odukwe A. O. and Agunwamba J. C. "Modification of Sequence of Unit Operations in Mechanized Palm Fruit Processing", *Nigerian Journal of Technology*, Vol. 30, No. 3, 2011, pp. 41-49.
- [8] Stephen K. A and Emmanuel S. "Modification in the Design of an already Existing Palm Nut-Fibre Separator", *African Journal of Environmental Science and Technology*, Vol. 3, No.11, 2009, pp. 387-398.
- [9] Ogblechi S. R and Ige M. T. "Development of a Model to Predict the Shear Force of a Horizontal Mechanical Digester", *International Journal of Science, Technology and Society*, Vol. 2, No. 6, 2014, pp. 174-178.
- [10] Bello R. S., Bello M. B., Essien B. A., Saidu M. J., Economic Potentials of Oil Palm Production and Machinery Use in UDI, Enugu State, Nigeria, *Science Journal of Business and Management. Special Issue: Sustainable Entrepreneurial Developments in Agribusiness*. Vol. 3, No.5-1, 2015, pp. 16-20.
- [11] Khurmi R. S and Gupta J. K, "A Textbook of Machine Design"; Eurasia Publishing House (Pvt.) Ltd: New Delhi. 2005, pp 53-86, pp 120-180, pp 181-223 and pp 509-758.
- [12] Badmus, G. A., "An Overview of Oil Palm Processing in Nigeria", *Proceedings of Agricultural Engineering in Nigeria: Thirty years of University of Ibadan experience*, 2002, pp. 76-87.
- [13] Asoiro F. U and Udo U. C., "Development of Motorized Oil Palm Fruit Rotary Digester"; *Nigerian Journal of Technology*, Vol.32, No.5, 2013, pp. 455-462.
- [14] Okafor Basil E., "Development of Palm Oil Extraction System", *International Journal of Engineering and Technology*, Vol. 5 No. 2, 2015, pp. 68-75.